

E4-WM5-Y630A00

MOUNTING INSTRUCTION



This instruction is for both left rear (driver) 25-284584 and right rear (passenger) 25-284591 B8 8100 shocks. A bill of materials of the included mounting part kits is shown on the next page.

IMPORTANT! READ THIS FIRST!

Installation of shock absorbers requires special tools and expert knowledge. Accordingly, installation of all BILSTEIN products must be performed by a qualified suspension specialist.

When replacing other brands, BILSTEIN shock absorbers should always be installed as a set. All BILSTEIN products must only be used for the specific, intended application as indicated in the application guide. **Any use of any BILSTEIN product other than for its intended use may result in serious bodily injury or death.**

Always use a chassis hoist for the installation of BILSTEIN products and make certain that the raised vehicle is securely attached to the hoist and/or supported to prevent the vehicle from slipping, falling, or moving during the installation process.

If you choose to install any BILSTEIN product without the necessary special tools, expertise or chassis hoist, you may subject yourself to the risk of serious bodily injury or death. If you elect not to use a chassis hoist, at least make sure the vehicle is on level ground, that all tires on the ground during installation are blocked to prevent movement, that at least two tires are on the ground at all times, and that adequately secured safety stands (jack stands) are used to support the chassis. **NEVER** get under the vehicle until you have checked to make sure all of these steps are performed.

BILSTEIN suspension products are gas-filled and are highly pressurized.

- Never place any BILSTEIN product in a vise or use a clamp on any BILSTEIN product.
- Never apply heat near any BILSTEIN product.
- Never attempt to open or repair any BILSTEIN product, in order to prevent **serious bodily injury or death.**

Any attempt to misuse, misapply, modify, or tamper with any BILSTEIN suspension product voids any warranty and **may result in serious bodily injury or death.**

While installing any BILSTEIN product:

- Do not use impact tools for loosening or tightening fasteners, because this may destroy the screw threads.
- Self-locking fasteners must only be used **once!**
- Reuse original equipment components only if they are in good condition, otherwise replace them with new components.
- Never remove the slight film of oil on the piston rod and seal.
- All mounting fasteners for shocks and struts must be securely tightened before the vehicle is operated.

After installing any BILSTEIN product:

- The suspension caster and camber must be checked and/or adjusted to comply with the vehicle manufacturer's specifications.
- The (load dependent) brake compensator and the anti-lock brake system must be checked and/or reset to comply with the vehicle manufacturer's specifications.
- The headlight aim must be checked and adjusted.

B8 8100 bypass shocks feature a proprietary BILSTEIN zinc plated finish. This finish must be serviced in order to maintain its luster. Particularly in moist climates, a protective coating, such as a wax or lubricating oil should be periodically applied to prevent tarnishing. This finish is not covered under warranty.

It is normal to hear a slight audible clicking noise during compression and rebound strokes in the B8 8100 bypass shocks, most notably during low velocity events. This is due to the internal check pistons opening and closing to create the externally adjustable compression and rebound zones.

E4-WM5-Y630A00 MOUNTING INSTRUCTION

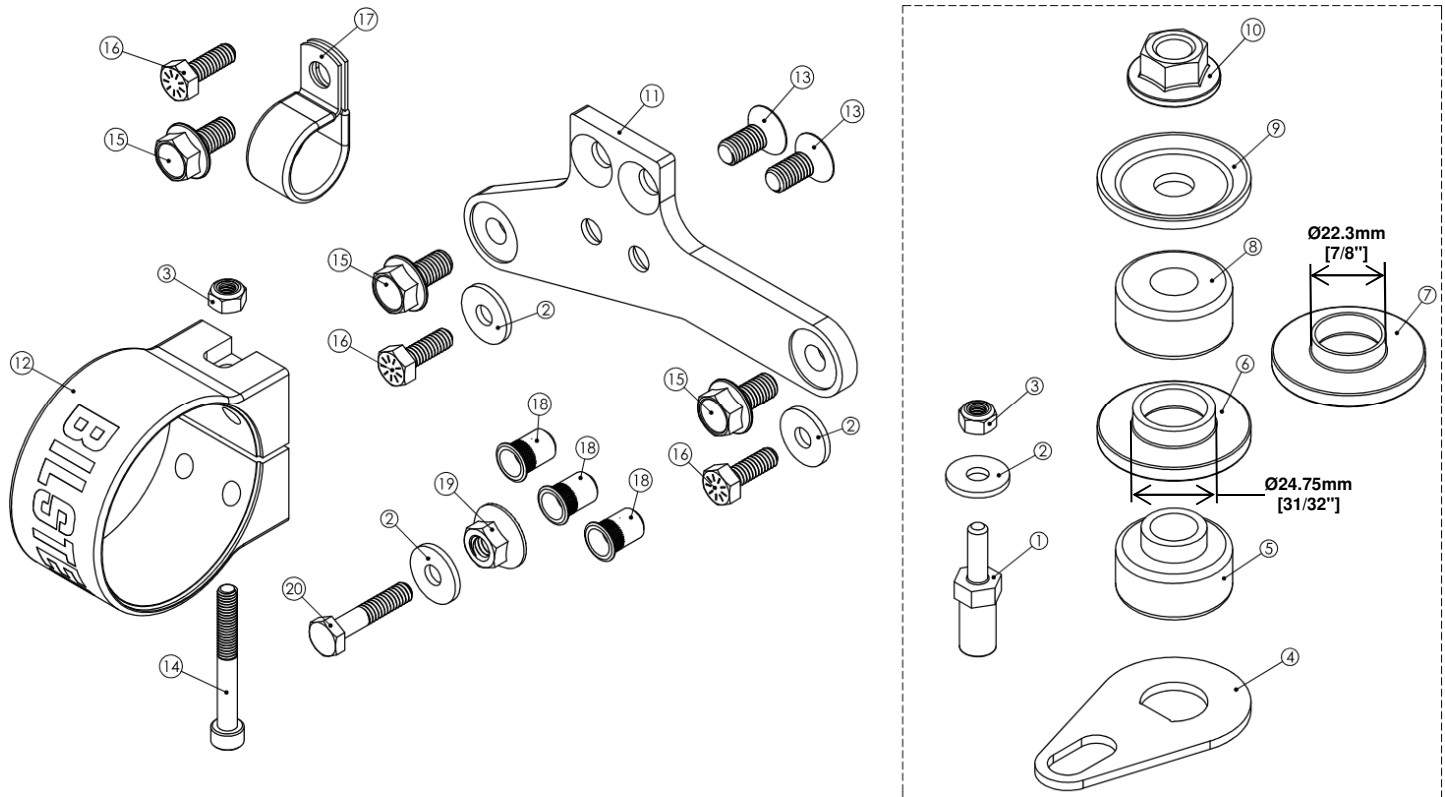

Items in the dotted line are bagged separately.

Bill of Materials		
Item #	Description	Qty
1	Anti Rotation Pin	1
2	Washer; 1/4" ID x 3/4" OD	4
3	Nylock; M6x1	2
4	Anti Rotation Plate	1
5	Bushing; Lower	1
6	Alignment Washer; '10-	1
7	Alignment Washer; '03-'09	1
8	Bushing; Upper	1
9	Concave Washer	1
10	Flange Locknut; M12X1.25	1
11	Reservoir Mount Plate; Rear	1
12	Reservoir Clamp	1
13	Flat Head Screw; M8x1.25; L=18	2
14	Socket Head Cap Screw; M6x1; L=50mm	1
15	Flange Head Cap Screw; M8x1.25; L=16mm	3
16	Hex Head Cap Screw; 1/4"-20; L=3/4"	3
17	Loop Clamp; Hose; 7/8" Dia.	1
18	Threaded Insert; 1/4"-20 Internal Thread	3
19	Serrated Flange Nut; 5/16"-18	1
20	Hex Head Cap Screw; 1/4"-20; L=1 1/4"	1

B8 8100 bypass shock installation procedure:

B8 8100 bypass shocks are corner specific. The step by step procedure is shown with pictures of the right side, and in some cases, pictures of the left. See pages 20 and 21 for the end result.

- A. Remove the existing shock from the vehicle following all procedures in the vehicle manufacturer's service manual. Inspect the OE lower shock bolt/washer for any damage or excessive wear. If these components are in good condition, save them for reuse later. If damage or excessive wear is present on any of these components, purchase the required replacement OE components.
- B. Place the Anti Rotation Pin (BOM item #1) into the frame hole circled in red below. This hole is towards the front of the shock mount hole.



Right side depicted. Left side is a mirror image.

- C. Hold the Anti Rotation Pin with a ½" or 13mm deep socket. Place a Washer (BOM item #2) over the threaded stem from the top side of the frame. Thread the Nylock (BOM item #3) onto the stem. Then, hold the Anti Rotation Pin assembly towards the rear of the vehicle and tighten the Nylock with a 10mm ratcheting wrench.
Torque the Nylock to 7 ft-lb (10 Nm).



Right side depicted. Left side is a mirror image.

E4-WM5-Y630A00 MOUNTING INSTRUCTION



- D. Slide the Anti Rotation Plate (BOM item #4) over the threaded pin and onto the shock body as shown below. Verify the D-ring hole in the plate seats over the D-ring boss at the base of the pin. Failure to lock this D-ring into place as shown below may cause your shock to rotate and contact the E-Brake cable as well as other components on the vehicle.

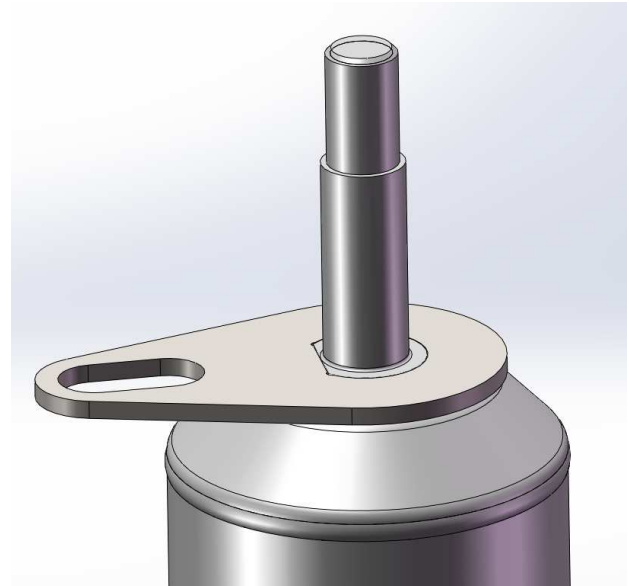
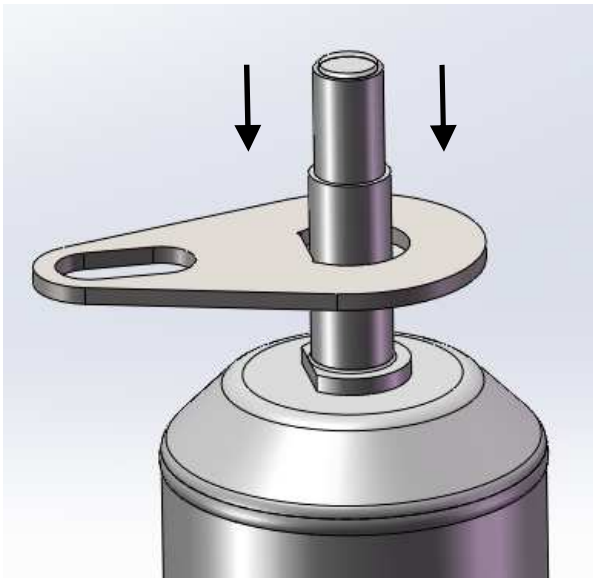

- E. Slide the Lower Bushing (BOM item #5) and the appropriate Alignment Washer for your vehicle (BOM item #6 or #7 depending on year; see BOM on page 2) over the threaded pin on the shock body as shown below.

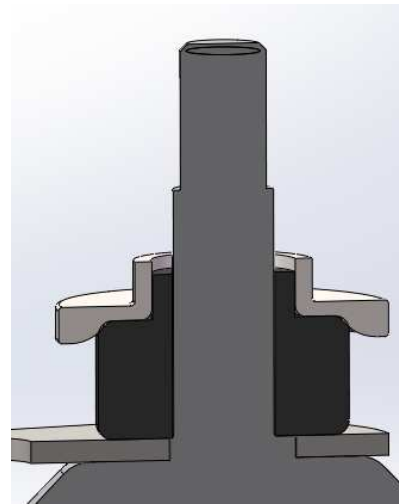

- F. Install the lower shock mount and thread in the OE lower shock bolt/washer that was removed in step A. Thread in until the lower shock mount is almost snug, but don't tighten yet.

E4-WM5-Y630A00 MOUNTING INSTRUCTION



- G. Then, using some force, compress the shock and place the threaded pin on the shock body through the chassis mount. Guide the Anti Rotation Plate (BOM item #4) so it captures the Anti Rotation Pin (BOM item #1) and carefully center the Alignment Washer (BOM item #6 or #7) in the chassis mount hole as shown below.



Right side depicted. Left side is a mirror image.

- H. Slide the Upper Bushing (BOM item #8) over the threaded pin, followed by the Concave Washer (BOM item #9). Verify the Concave Washer is installed concave side up as shown below. Then thread the Flange Locknut (BOM item #10) onto the threaded pin on the shock body. Tighten the Flange Locknut using an 18mm ratcheting wrench. **Torque the Flange Locknut to 20 ft-lb (27 Nm).**

You should now have the following:



Right side

E4-WM5-Y630A00 MOUNTING INSTRUCTION



Left side

- I. With both upper and lower shock mounts secured, and with the rear suspension drooped out, make sure the Anti Rotation Pin is not contacting the Anti Rotation Plate or shock body. If it is contacting, loosen the Nylock (BOM item #3) and slide the Anti Rotation Pin forward slightly until there is a small gap (~1/16"). Re-torque Nylock according to step C.

E4-WM5-Y630A00 MOUNTING INSTRUCTION



J. You should now have both shocks installed as shown below.



Left Rear



Right Rear



E4-WM5-Y630A00 MOUNTING INSTRUCTION



For 4Runner [Steps K-L can be skipped for GX460. Steps K-N can be skipped for '03-'09 4Runner and GX470]

- K. In order to install the reservoirs, the following plastic pieces need to be removed to gain access to 2 frame holes that will be used for the reservoir mounting.



Left side



Right side

- L. Remove the 5 screws holding the black plastic piece under the rear quarter panel. They are circled in red in the pictures below. The clip in the red square can be removed to further ease installation, but its removal is not required. The plastic piece can be rotated out of the way with it still fastened.



Right side depicted. Left side is a mirror image.



E4-WM5-Y630A00 MOUNTING INSTRUCTION



Right side depicted. Left side is a mirror image.

For Lexus GX460 [Steps M-N can be skipped for 4Runner and GX470]

- M. In order to install the reservoirs, the following plastic pieces need to be removed to gain access to 2 frame holes that will be used for the reservoir mounting.



Left side



Right side

E4-WM5-Y630A00 MOUNTING INSTRUCTION



- N. Remove the 5 screws holding the mud flaps and black plastic piece under the rear quarter panel. They are circled in red in the pictures below.



Right side depicted. Left side is a mirror image.

- O. Once you've moved the panel out of the way, locate the holes on the vertical section of the frame rail. On the right side, they are either 10mm holes or threaded M8x1.25 holes depending on the year of your vehicle. On the left side, they are always threaded M8x1.25 holes.



Left side



Right side

Note: On GX470 models the air compressor assembly will need to be removed in order to install the reservoirs.



4Runner & GX460/470 Left Side Reservoir Installation Procedure

(Note, the reservoirs are not installed as a mirror image so step by step instructions with pictures of both sides are shown):

- P. Prepare the assembly below by applying non-permanent thread locker to two Flat Head Screws (BOM item #13). Mount the Reservoir Clamp (BOM item #12) to the Reservoir Mount Plate (BOM item #11) as shown below using the two Flat Head Screws. Tighten using a 5mm hex.
Torque both Flat Head Screws to 16 ft-lb (22 Nm).
- Q. Place the Nylock (BOM item #3) in the upper slot of the Reservoir Clamp as shown below. Then place the Socket Head Cap Screw (BOM item #14) through the hole in the Reservoir Clamp, threading it into the Nylock. Thread in a few turns for now with a 5mm hex but leave loose enough so the reservoir can be installed in the next step. Apply non-permanent thread locker to one Flange Head Cap Screw (BOM item #15) and place it through the hole in the Reservoir Mount Plate as shown below. Note that the counterbores do not serve a purpose for the left side installation and are there for the right side if the Threaded Inserts are used.

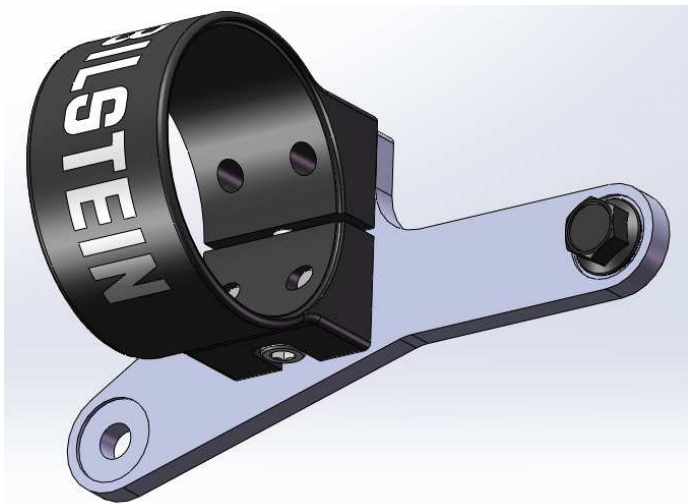

Front side

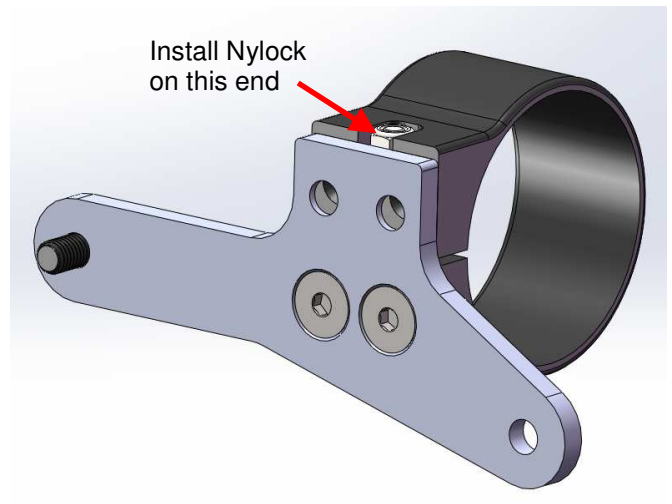

Back side

- R. Slide the reservoir through the Reservoir Clamp as shown below. Snug up the Socket Head Cap Screw (BOM item #14) so that the reservoir bracket assembly doesn't fall off the reservoir. But leave loose enough to be able to slide the reservoir back and forth in the Reservoir Clamp.

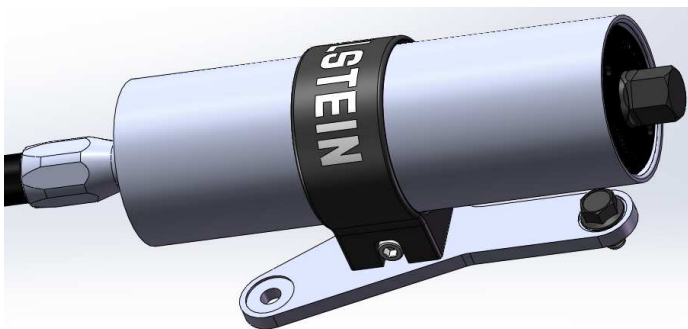

Front side

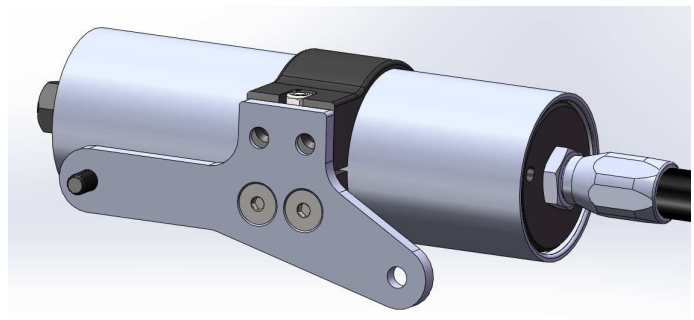

Back side

E4-WM5-Y630A00 MOUNTING INSTRUCTION



- S. Place the entire reservoir/bracket assembly under the rear quarter panel and mount to the two threaded holes in the frame. Use an open ended 13mm wrench to thread in the Flange Head Cap Screw. Apply non-permanent thread locker to the second Flange Head Cap Screw, then place it through the other hole in the Reservoir Mount Plate and into the threaded hole in the frame. Now, slide the reservoir so that it's almost touching the rear body mount bracket as shown below. This should yield approximately 1/4" clearance to the fender on the front side.
Torque both Flange Head Cap Screws to 18 ft-lb (25 Nm).



- T. Once the reservoir has been positioned as shown and confirmed to not be contacting anything on the vehicle, tighten the Socket Head Cap Screw that was snugged down in step P.
Torque the Socket Head Cap Screw to 6 ft-lb (8 Nm).



4Runner & GX460/470 Right Side Reservoir Installation Preparation:

- U. The fasteners to be used are different depending on if the holes in your frame are threaded or not. They are either 10mm through holes or M8x1.25 threaded holes depending on the year of your vehicle. If they are 10mm through holes, there are some steps that need to be done to install Threaded Inserts. If the holes in your frame are threaded, skip to step AA for 4Runner/GX470 or step FF for GX460.

Process for installing Threaded Inserts into frame (complete this procedure for all Threaded Inserts)

- V. If you have access to a Threaded Insert gun or pliers, that may be preferable to set the provided Threaded Inserts. Otherwise, using the BOM items shown below and a 1/2" box end wrench, arrange them as shown and turn the 1/4"-20 hex head cap screw by hand until it is snug.

Note that the screw will pass through the serrated flange nut without engaging the threads. The threads will instead engage the Threaded Insert. The serrations on the flange nut prevent the Threaded Insert from rotating while setting it.

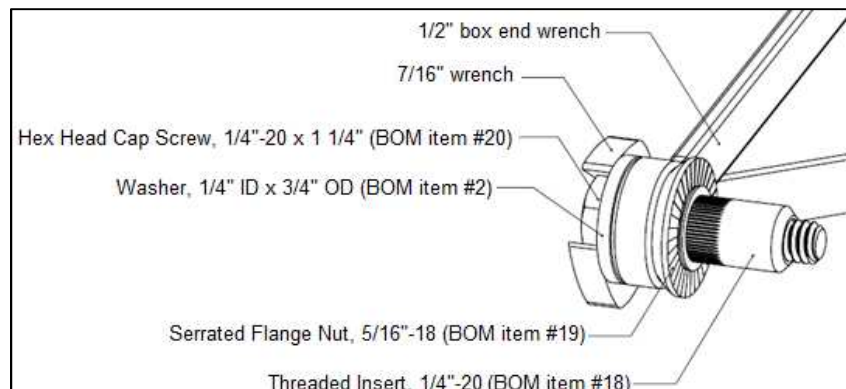
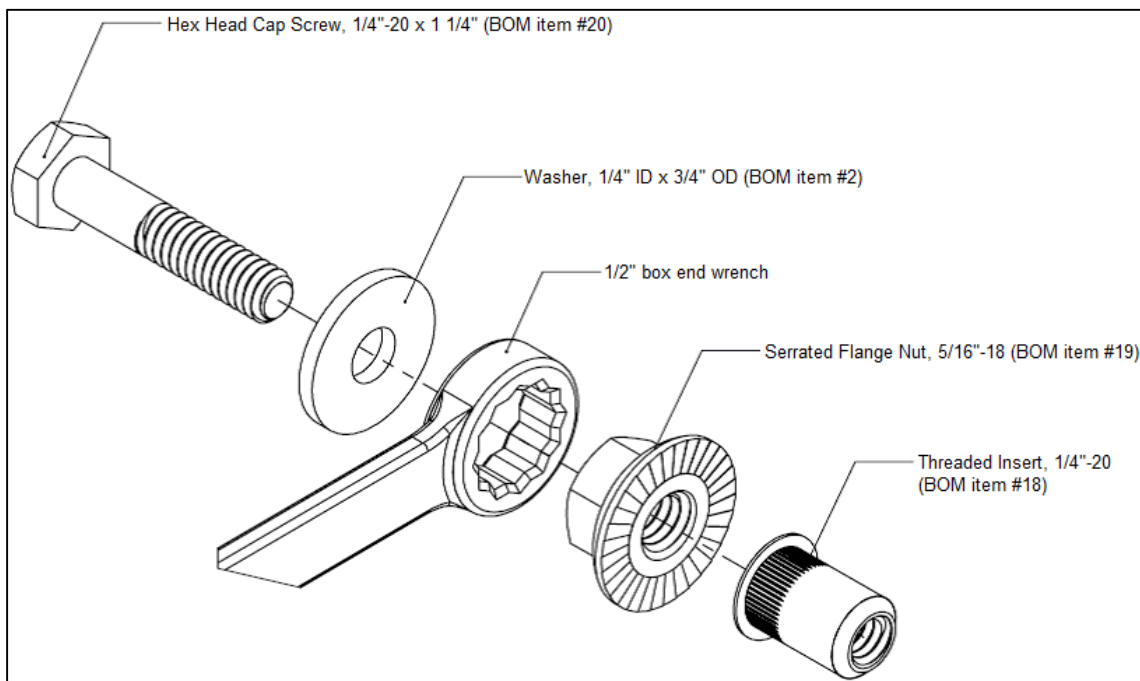

E4-WM5-Y630A00 MOUNTING INSTRUCTION



W. Place the Threaded Insert into the hole.



X. While keeping the Threaded Insert flange firm and parallel against the frame rail, tighten the screw using a 7/16" box end wrench or socket. Turn it 2.5 rotations to set the Threaded Insert. Tightening in 1/4 turn increments tends to work well.



Y. Remove the screw, washer, and flange nut. The Threaded Insert should now be rigidly fixed in the hole as shown below.



E4-WM5-Y630A00 MOUNTING INSTRUCTION



Z. Complete steps V-Y for the three places shown below:



Under rear quarter panel

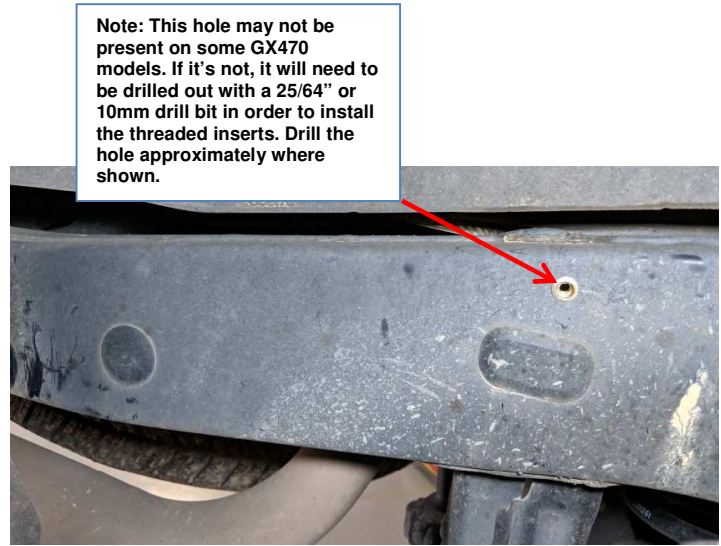

Note: This hole may not be present on some GX470 models. If it's not, it will need to be drilled out with a 25/64" or 10mm drill bit in order to install the threaded inserts. Drill the hole approximately where shown.

In wheel well

4Runner & GX470 Right Side Reservoir Installation Procedure:

AA. Prepare the following assembly by applying non-permanent thread locker on two Flat Head Screws (BOM item #13). Mount the Reservoir Clamp (BOM item #12) to the Reservoir Mount Plate (BOM item #11) as shown below using the two Flat Head Screws (BOM item #13). Tighten using a 5mm hex.

Torque both Flat Head Screws to 16 ft-lb (22 Nm).

BB. Place the Nylock (BOM item #3) in the upper slot of the Reservoir Clamp as shown below. Then place the Socket Head Cap Screw (BOM item #14) through the hole in the Reservoir Clamp, threading it into the Nylock. Thread in a few turns for now with a 5mm hex but leave loose enough so the reservoir can be installed in the next step. Note that the counterbores are facing the frame for this side. This is so the plate will still mount flush to the frame if the Threaded Inserts are required.

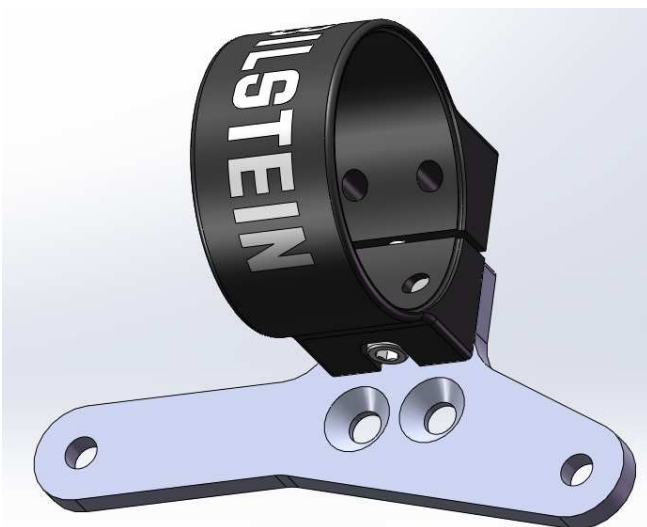

Front side

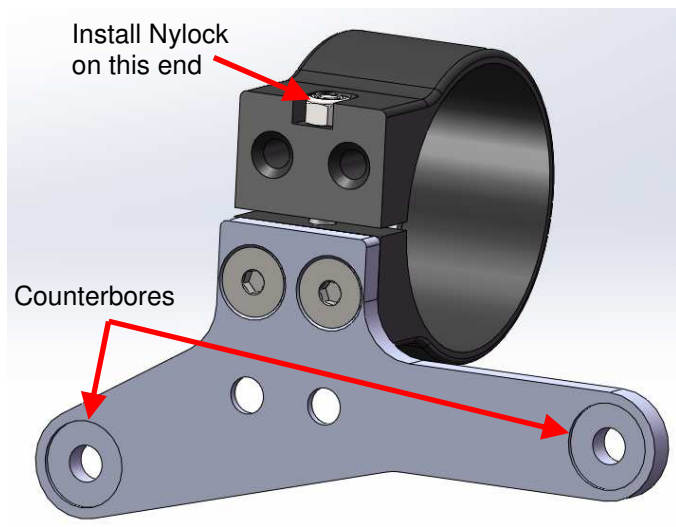

Back side

E4-WM5-Y630A00 MOUNTING INSTRUCTION



CC. Slide the reservoir through the Reservoir Clamp as shown below. Snug up the Socket Head Cap Screw (BOM item #14) so that the reservoir bracket assembly doesn't fall off the reservoir. But leave loose enough to be able to slide the reservoir back and forth in the Reservoir Clamp.

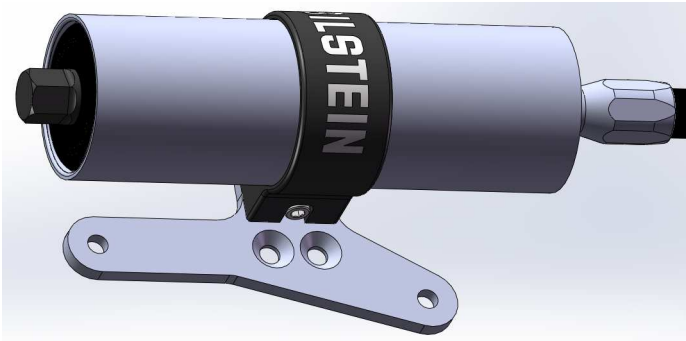

Front side

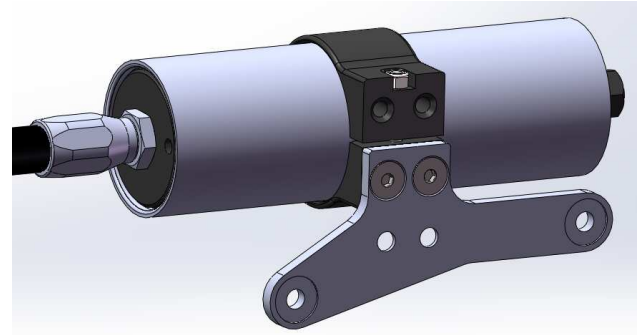

Back side

DD. Place the entire reservoir/bracket assembly shown above under the rear quarter panel and mount to the two holes in the frame. If threaded holes exist, apply non-permanent thread locker to two of the Flange Head Cap Screws (BOM item #15) and use a 13mm wrench to mount the assembly to the frame. If Threaded Inserts were installed, apply non-permanent thread locker to two of the Hex Head Cap Screws (BOM item #16) and use two of the Washers (BOM item #2) and a 7/16" wrench to mount the assembly to the frame. Now, slide the reservoir back until there is approximately 1/4" clearance to the exhaust hanger bracket. This should yield more than 1/4" clearance to the fender on the front side.

**Torque both Flange Head Cap Screws to 18 ft-lb (25 Nm)
OR both Hex Head Cap Screws to 14 ft-lb (19 Nm).**

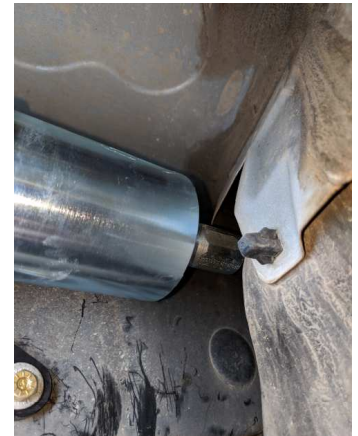

Depicted above with Hex Head Cap Screws and Washers (Threaded Inserts were used)

EE. Once the reservoir has been positioned as shown and confirmed to not be contacting anything on the vehicle, tighten the Socket Head Cap Screw that was snugged down in step CC.

Torque the Socket Head Cap Screw to 6 ft-lb (8 Nm).



GX460 Right Side Reservoir Installation Procedure:

FF. Prepare the assembly below by applying non-permanent thread locker to two Flat Head Screws (BOM item #13). Mount the Reservoir Clamp (BOM item #12) to the Reservoir Mount Plate (BOM item #11) as shown below using the two Flat Head Screws. Tighten using a 5mm hex.

Torque both Flat Head Screws to 16 ft-lb (22 Nm).

GG. Place the Nylock (BOM item #3) in the upper slot of the Reservoir Clamp as shown below. Then place the Socket Head Cap Screw (BOM item #14) through the hole in the Reservoir Clamp, threading it into the Nylock. Thread in a few turns for now with a 5mm hex but leave loose enough so the reservoir can be installed in the next step. Apply non-permanent thread locker to one Flange Head Cap Screw (BOM item #15) and place it through the hole in the Reservoir Mount Plate as shown below.

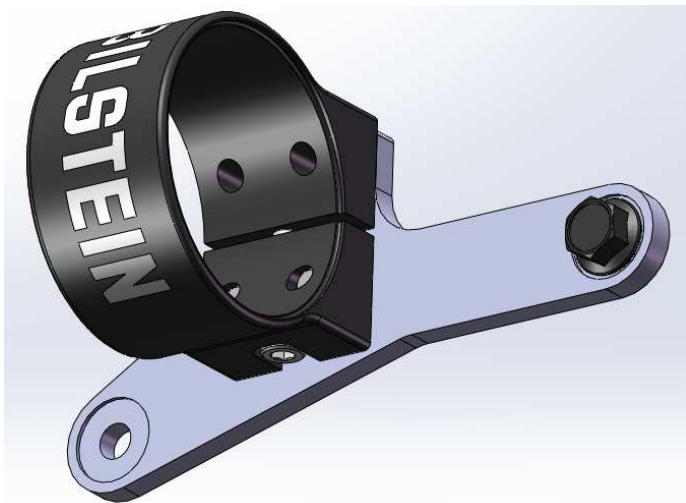

Front side

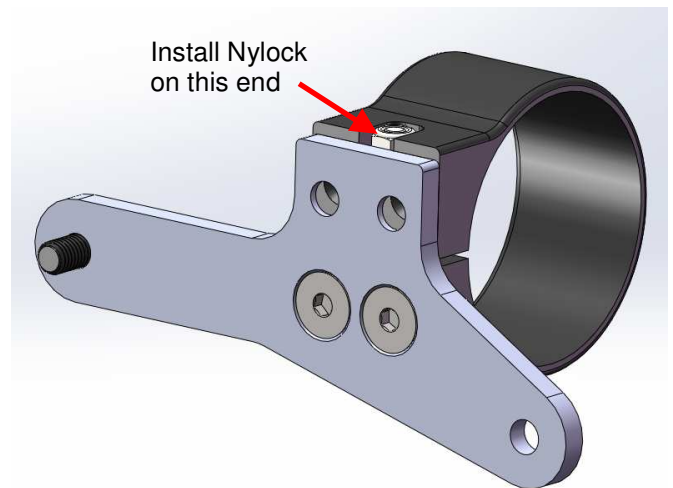

Back side

HH. Slide the reservoir through the Reservoir Clamp as shown below. Snug up the Socket Head Cap Screw (BOM item #14) so that the reservoir bracket assembly doesn't fall off the reservoir. But leave loose enough to be able to slide the reservoir back and forth in the Reservoir Clamp.

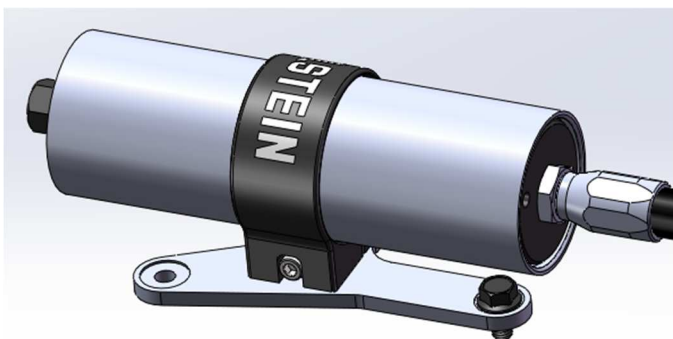

Front side

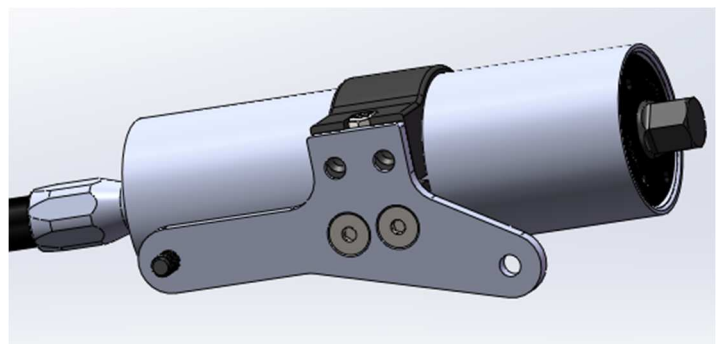

Back side

E4-WM5-Y630A00 MOUNTING INSTRUCTION



- II. Place the entire reservoir/bracket assembly shown above under the rear quarter panel and mount to the two holes in the frame. If threaded holes exist, apply non-permanent thread locker to two of the Flange Head Cap Screws (BOM item #15) and use a 13mm wrench to mount the assembly to the frame. If Threaded Inserts were installed, apply non-permanent thread locker to two of the Hex Head Cap Screws (BOM item #16) and use two of the Washers (BOM item #2) and a 7/16" wrench to mount the assembly to the frame. Now, slide the reservoir back until there is approximately 1/4" clearance to the body mount bracket.

Torque both Flange Head Cap Screws to 18 ft-lb (25 Nm)

OR both Hex Head Cap Screws to 14 ft-lb (19 Nm).



- JJ. Once the reservoir has been positioned as shown and confirmed to not be contacting anything on the vehicle, tighten the Socket Head Cap Screw that was snugged down in step HH.

Torque the Socket Head Cap Screw to 6 ft-lb (8 Nm).



Hose Clamp Installation Procedure (both sides)

KK. Place the Loop Clamp (BOM item #17) around the hose as shown below. If the hole is threaded, apply non-permanent thread locker to one of the Flange Head Cap Screws (BOM item #15) and use a 13mm wrench to mount the hose to the frame. If a Threaded Insert was installed, apply non-permanent thread locker to one of the Hex Head Cap Screws (BOM item #16) and use a 7/16" wrench to mount the hose to the frame.

Torque either Cap Screw to 14 ft-lb (19 Nm).



Right side depicted. Left side is a mirror image, except for KDSS models.

Note: On the left side of KDSS models there is a Flange Head Cap Screw already present. Remove the screw, apply non-permanent thread locker, and use it to install the Loop Clamp as shown below.

Torque Flange Head Cap Screw to 14 ft-lb (19 Nm)



LL. Re-install the plastic panels that were removed in steps K-N (if applicable).

MM. With the vehicle back on the ground, tighten the OE lower shock bolt/washer that was installed in step F.

Torque OE lower shock bolt to factory specifications. This completes the installation.

E4-WM5-Y630A00 MOUNTING INSTRUCTION



Final left rear (driver) 25-284584 B8 8100 shock installed on 4Runner and GX460/470:

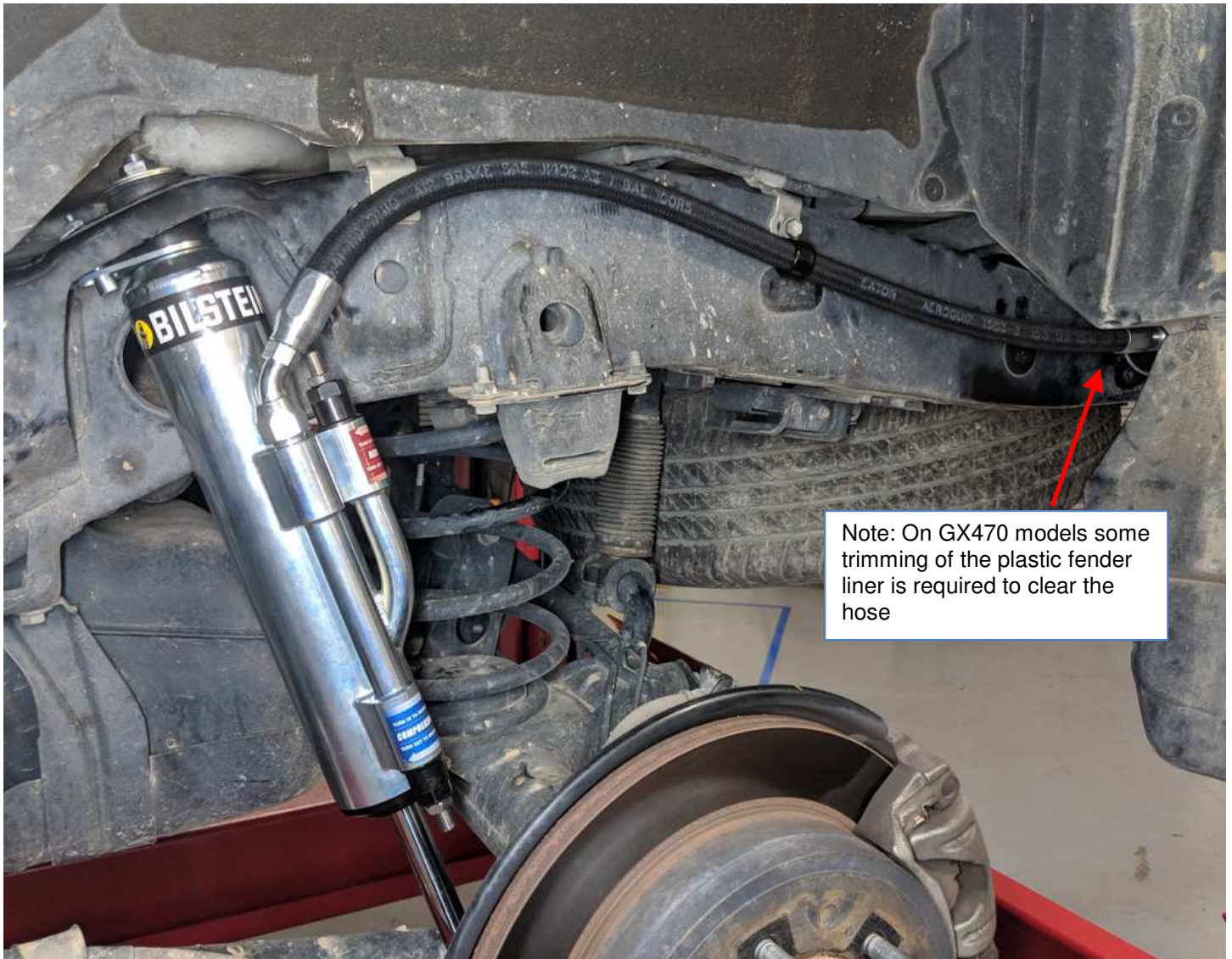

Note: On GX470 models some trimming of the plastic fender liner is required to clear the hose

2016 4Runner KDSS model depicted

E4-WM5-Y630A00 MOUNTING INSTRUCTION



Final right rear (passenger) 25-284591 B8 8100 shock installed on 4Runner and GX470:



2016 4Runner KDSS model depicted

Final right rear (passenger) 25-284591 B8 8100 shock installed on GX460:



E4-WM5-Y630A00

MOUNTING INSTRUCTION



B8 8100 bypass shocks allow the user to tune the damping for the best possible ride quality of their vehicle. The shocks offer multiple zones of compression and rebound damping, depending upon the bypass configuration. The factory setting is:

Rebound- 5 full turns out from fully closed.
Compression- 6 full turns out from fully closed.

B8 8100 bypass adjustment procedure:

1. Using an Allen key, hold the adjuster screw from rotating. Loosen the jam nut from the bypass adjuster housing. Back it off far enough that you can make the adjustment without the jam nut bottoming out.
2. Rotate the Allen key to make the desired adjustment.

TURN IN (Clockwise) the adjuster screw to **INCREASE** damping

TURN OUT (Counter Clockwise) the adjuster screw to **DECREASE** damping

3. Tighten the jam nut against the bypass adjuster housing while using the Allen key to hold the adjuster screw from rotating.

Make sure the bypass adjuster housing does not loosen during the adjustment process. It may be necessary to hold the bypass adjuster housing with the appropriate wrench while loosening the jam nut.

Anti Rotation component service:

The Anti Rotation Pin (BOM item #1) and Anti Rotation Plate (BOM item #4) are wear items and will need to be replaced periodically depending on usage. Check for wear every 20,000 miles and replace components if they show excessive signs of wear.

B8 8100 bypass service:

For service of your B8 8100 bypass shocks, please contact:

THYSENKRUPP BILSTEIN OF AMERICA
14102 Stowe Dr.
Poway, CA 92064, USA

Toll Free: 1-800-537-1085
bilsteinus.com